

Specification sheet

XF FTT

6X4 Tractor



ENGINES

XF 530 MX-13 (390 kW / 530 hp)

GVM¹⁾

27000 kg

Max. front 7500 kg

Max. rear 21000 kg

GCM²⁾

70000 kg

New Zealand, Southpac Trucks Ltd, www.spt.co.nz

CAB EXTERIOR

Super Space Cab with galvanised steel bumper, tinted glass and electric window openers. Main mirrors and wide angle mirrors electrically heated. Cab width 2490mm; LED Headlights; LED daytime running lights; Fog lights; Skylights; Electrically adjustable main mirrors.

Optional

- Space Cab
- Cab suspension air
- Front view mirror
- Fog lights and cornering lights
- Skylights
- One hazard beacon light at co-driver side
- One hazard beacon light at driver side
- Two hazard beacon lights

AERODYNAMICS

Adjustable roof air deflector; Side Collars

COLOURS

Cab colour M8870 Ice White; Head lamp panel and bumper: Ice White; Chassis colour Black.

Optional

- Cab - Customer fleet colour
- Chassis - Red or Grey

CAB INTERIOR

Cab interior trim colour Exclusive; Cab interior decoration Argenta (silver); Driver seat: Xtra Leather Air; Co-driver seat: Xtra Leather Air; Steering wheel: Leather, Exclusive; Automatic Temperature Control and airco; Roof hatch glass, manual control; Pollen filter.

Optional

- Steering wheel, leather, colour black
- Cab interior trim colour, Dark Sand
- Cab interior decoration, Black Rock
- Cab interior decoration, Rustica (wood grain)
- Driver seat: Super Air
- Driver seat: Leather Air
- Co-driver seat: Comfort Air
- Co-driver seat: Luxury Air
- Co-driver seat: Super Air
- Co-driver seat: Xtra Leather Air
- Seat belts red
- Third seat
- Refrigerator
- Lower bunk mattress Xtra comfort
- PL light in cab ceiling
- Automatic Cab Climate Control

COMMUNICATION AND DRIVING MANAGEMENT

Adaptive Cruise Control with FCW and AEBS; Speed limiter setting 100 km/h; Antennas: AM/FM, 2x GSM, CB aerial; Truckphone; Pioneer radio with Apple Carplay, Luxury speaker system with 6 speakers.

SAFETY AND SECURITY

Lane Departure Warning System; Vehicle stability control; Basic engine immobiliser system. Air bag (driver) and 2 seat belt tensioners

Optional

- Front camera system
- Side camera system
- Reverse warning

SUSPENSION AND AXLES

Front axles load 7.10 + 7.10 t; Rear: 2x 9.00 t, air suspension, SR1360T.

Optional

- Axle load monitoring

WHEELS AND TYRES

Front axle 1: 275/70R22.5; Rear axle 1: 275/70R22.5; Rear axle 2: 275/70R22.5; Goodyear tyres; Alcoa Dura Bright alloy wheels.

Optional

- Alcoa brushed alloy wheels
- Tyre types and sizes
- Michelin or Continental

DRIVELINE

Engine MX-13, multi torque 6 cylinder diesel engine, 12.9 litres. Output 390 kW (530 hp) at 1675 rpm. Maximum torque 2600 Nm at 1000-1460 rpm; Exhaust emission Euro 6; Engine idle shutdown, 5 minutes; Automated gearbox, TraXon, 12 speeds; Gearbox ratio 12.92-0.77; Rear axle ratio 3.40.

Optional

- Automated gearbox, TraXon, 16 speeds

BRAKE SYSTEM

MX Engine brake; Ventilated disc brakes front and rear. Dual circuit air system with electronic control (EBS). Twin cylinder air compressor with heated dryer and economy mode.

Optional

- ZF Intarder

CHASSIS

Wheelbase 4.30 m / rear overhang 1.65 m; Side member height 260 mm; Exhaust pipe horizontal, low; Alu fuel tank 430L, height 620 mm; Rear mudguards; LED Worklamp; Spray suppression; Front underrun protection (FUP); Catwalk with step; AdBlue tank 90 litres on left-hand mudguard; Battery box behind the cab, no spare wheel carrier.

Optional

- Exhaust pipe Vertical, high

DRAWBAR AND TRAILER EQUIPMENT

Jost fifth wheel JSK37C cast iron, height 150mm with 26mm mounting plate; Fifth wheel KA dimension 370mm; King pin diameter 2"; Pneumatic trailer connection C-type; Electric connection 24 V / 2x7 pins. DAF rear mudguards.

POWER TAKE-OFF (PTO)

Optional

- PTO types and positions

ELECTRICAL POWER SUPPLY

Alternator 80 A, batteries 2x 175 Ah.

Optional

- Alternator 120 A
- Batteries 2x230Ah
- Alternator 150 A

GVM AND GCM

Chassis weight related technical GVM max 25600 kg; Driveline related max GCM 70000 kg class 2.

APPLICATION CONDITIONS

Air intake on the cab roof.

Optional

- Cyclonic air intake behind the cab

SERVICE AND MAINTENANCE

Standard Warranty takes care of 1 year complete vehicle, 2nd & 3rd year driveline.



Go to [DAF.com](https://www.daf.com) to configure your own perfect DAF.

XF FTT

6X4 Tractor

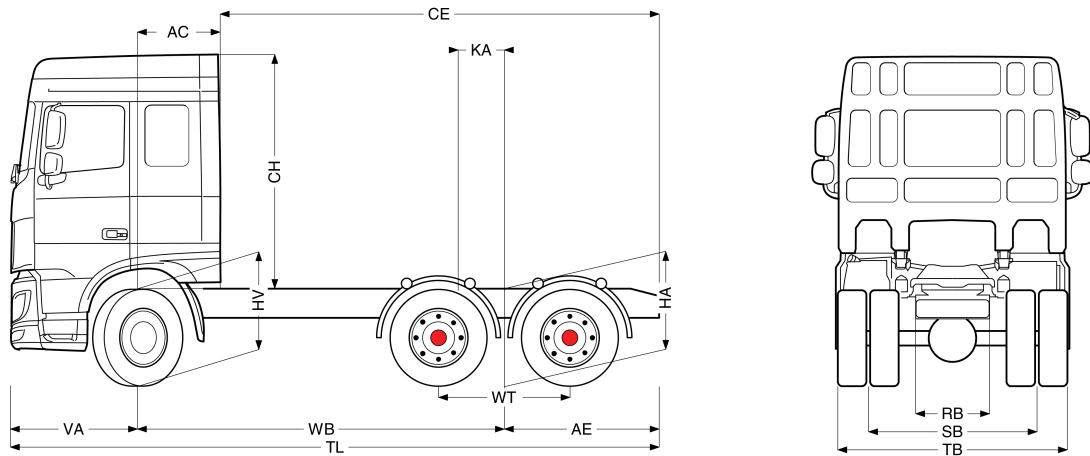

	Wheelbase - AE		Unladen weight ⁹⁾			Gross Carrying Capacity			Variable dimensions								
	WB	AE ⁵⁾	Front	Rear	Total	Front	Rear	Total	AC	CE	CH ⁶⁾	KA ⁷⁾	TL	HA ⁸⁾	HA ⁹⁾	TK ¹⁰⁾	TW ¹¹⁾
SPACE CAB	3.90	1.65	5267	3859	9126	2733	17141	17874	0.88	4.67	2.51	0.36	6.92	1.07	1.04	13.76	15.13
	4.55	1.65	5255	3918	9173	2745	17082	17827	0.88	5.32	2.51	0.36	7.57	1.07	1.05	15.45	16.84
SUPER SPACE CAB	3.90	1.65	5325	3859	9184	2675	17141	17816	0.88	4.67	2.89	0.36	6.92	1.07	1.04	13.76	15.13
	4.55	1.65	5313	3918	9231	2687	17082	17769	0.88	5.32	2.89	0.36	7.57	1.07	1.05	15.45	16.84

OTHER DIMENSIONS	VA: 1.37	WT: 1.40	HV ¹²⁾ : 1.04	HV ¹³⁾ : 1.00	RB: 0.79	SB: 1.82	TB ¹⁴⁾ : 2.48
------------------	----------	----------	--------------------------	--------------------------	----------	----------	--------------------------

- 1) GVM in conformity with registration documents.
- 2) GCM in conformity with registration documents.
- 3) Axle load with standard tyre size.
- 4) Chassis and cab weight calculated with: Standard specification items only with 0 litres of fuel, 0 litres of AdBlue and driver of 0 kg, tolerance $\pm 3\%$. Changing of the specification can have major impact on vehicle weight.
- 5) Other AE dimensions may be available for shown WB.
- 6) Cab height is measured from frame member to closed cabin roof hatch.
- 7) Calculate customer specific KA with TOPEC.
- 8) Unladen height at centre of driven axle(s).
- 9) Laden height at centre of driven axle(s).
- 10) TK = turning circle between kerbs.
- 11) TW = turning circle between walls.
- 12) Unladen height at centre of front axle(s).
- 13) Laden height at centre of front axle(s).
- 14) TB is overall width at rear. (At lower cab step 255).

Depending on the vehicle configuration a specific option may not be possible. The availability and specification of this vehicle may differ per country. For further information please contact the DAF organisation. Pictures and technical illustrations are not binding in detail and can differ from the standard specification. Subject to modification without prior notice.